

Flush-mounted pressure and level transmitter - PZM / VRM modular system...Series 100 -

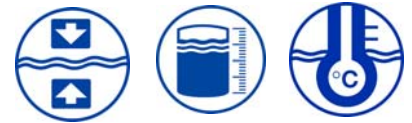
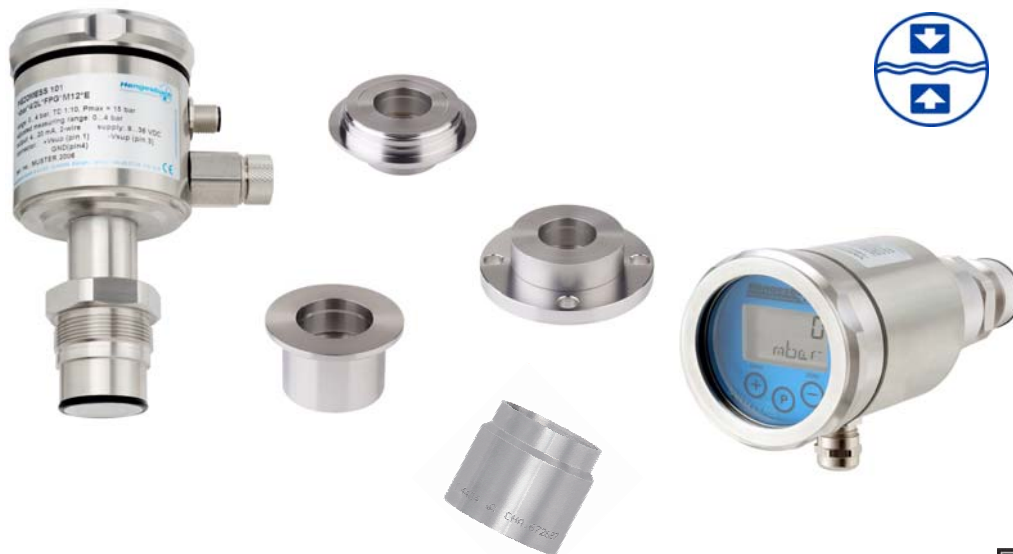

CHARACTERISTICS

- MODULAR, FLUSH-MOUNTED CONNECTION CONCEPT - 1 BASIC DEVICE FOR VARIOUS CONNECTION ADAPTORS
- PZM 100/101: PIEZO-RESISTIVE WITH WELDED STAINLESS STEEL MEMBRANE FOR LEVEL MEASUREMENTS, FOR HIGHLY OVERLOAD-RESISTANT APPLICATIONS
- VRM 100/101: CAPACITIVE WITH CERAMIC SENSOR FOR PROCESS PRESSURE SENSOR UNIT, FOR HIGHLY OVERLOAD-RESISTANT APPLICATIONS
- RAPID ADJUSTMENT OF "ZERO" AND "RANGE", TURN-DOWN RATE 1 : 10
- COMPACT, ROBUST, HIGHLY OVERLOAD-RESISTANT IN IP67 STAINLESS STEEL FIELD HOUSING
- EASY TO CLEAN, FDA MATERIALS, EHEDG CERTIFICATION
- INTEGRATED OR EXTERNAL ON-SITE DISPLAY AND OPERATING MODULE "OPUS" - FOR EASIER OPERATION

DESCRIPTION

The digital pressure and level transmitters **PIEZOMESS PZM / VARIMESS VRM - Series 100**, with their O-ring seals, are suitable for pressure and level measurements without dead spaces, under strict cleanliness conditions, as well as for viscous and crystallising media. They have a modular, flush-mounted connection concept with various adaptors. An additional temperature sensor as a secondary measuring element provides the temperature measured on the sensor available on the display as additional information.

The **PIEZOMESS PZM / VARIMESS VRM - Series 100** consists of one basic device, which can be combined with various application-specific adaptors, e.g. welding sockets, DRD, VARIVENT, DIN 11851, Clamp, Flange DIN, etc. In combination with the advantages of digital electronics, e.g. a large measuring range and on-site adjustability, this concept results in clearly reduced storage space and spare parts and thus to a cost reduction in materials administration. During operation, various pressure units can be shown on the local display (OPUS), along with the sensor temperature as a secondary process indicator. The display and operating module has either been integrated into the field housing or is available as an external housing with a plug connection. The sensor-specific data are stored in a reference data memory and are made available to the microprocessor for evaluation purposes.

The pressure sensors of the **PIEZOMESS PZM** series work according to the piezo-resistive measuring principle and are separated from the measuring material by a stainless steel membrane. The pressure is transmitted via an oil filling that is safe for use with food. All parts that come into contact with the medium have been welded. The **PIEZOMESS PZM** type series has been specially designed for level measurements.

The pressure sensors of the **VARIMESS VRM** series are robust and overload-protected ceramic membranes that work according to the capacitive method. The pressure to be measured acts on the sensor via the flush-mounted stainless steel membrane and the low-volume oil supply to the sensor. The system has a high overload capacity due to its special design. The type series **VARIMESS VRM** is intended for pressure measurements, where pressure surges and cavitations are common.

PN/PZM-VRM-100/D-e-08-1/1

Flush-mounted pressure and level transmitter - PZM / VRM modular system...Series 100 -



TECHNICAL DATA

General information								
Measuring principle / device type	- PIEZOMESS-PZM 100/101: Piezo-resistive - preferred for level measurements - VARIMESS-VRM 100/101: Ceramic-capacitive - preferred for pressure measurements							
Input								
Measuring ranges (depending on type of device)	PZM 100/101				VRM 100/101			
Nominal measuring ranges (bar)	relative	OSD	absolute	OSD	relative	OSD	absolute	OSD
	0.35 bar	1	0.35 bar	1	0... +1 bar	10	0... 2 bar	18
	1 bar	3	1 bar	3	-1/0... +1 bar	10	0... 20 bar	40
	2.5 bar	8	2.5 bar	8	-1/0... +4 bar	25	0... 70 bar	105
	5 bar	15	5 bar	15	-1/0... +10 bar	40		
	10 bar	30	10 bar	30	0... +40 bar	60		
	30 bar	90	30 bar	90	-1/0... +70 bar	105		
	100 bar	250	100 bar	250				
OSD = overload safety device (bar)								
Setting the measuring range	using the keyboard of the display / operating field (OPUS)							
Adjustable ranges	Measuring start zero: 0... 90% of the nominal measuring range, infinitely adjustable Measuring range: 10...100% of the nominal measuring range, infinitely adjustable (TD = 1:10)							
Overload safety device	- 1 bar and double superior limit value for PZM, higher overload safety on request - up to 40-fold overload resistance for VRM							
Bursting pressure DIN 16086	10-fold superior limit value, depending on type of device							
Output								
Output signal	4...20 mA-Signal, 2-wire							
Breakdown signal	optionally 3.6 mA, 22 mA, hold (last current is kept)							
Current limit	3.85 mA; 21.5 mA (normal operation)							
Integration time	(0,1,2,4,8,16,32,64,128 s) 0 - 128 s stepwise adjustable (response time after pressure jump)							
Measuring accuracy								
Reference conditions	according to DIN 16086 and DIN IEC 770							
Linearity, incl. hysteresis and repeatability, acc. to limit point method DIN IEC 770	- for PZM = $\pm 0.3\%$ of the limit value for the nominal measuring range, optionally $\pm 0.2\%$ - for VRM = $\pm 0.4\%$ of the limit value for the nominal measuring range * in the case of small absolute pressure ranges, special linearity indications are required							
Warm-up time	1 s							
Adjustment time (without attenuation)	320 ms (supply frequency 50 Hz selected) or 266 ms (supply frequency 60 Hz selected)							
Long-term drift	0.1% FS per year							
Thermal hysteresis	Zero point and measuring range in compensated temperature range 0...80°C $\leq \pm 0.2\%$ of the nominal value / 10 K (-20... + 80°C) for nominal measuring range from 4 bar onwards $\leq \pm 0.3\%$ of the nominal value / 10 K (-20... + 80°C) for measuring ranges of up to 0.6 bar							
Operating conditions								
Installation position	any							
Medium temperature	-40°C... + 125°C, 140°C max. for 1 h							
Environmental temperature	-40°C... + 80°C							
Storage temperature	-40°C... + 80°C							
Protection class EN 60529	IP 67 (with pressure compensation via FPG) IP 67 (with permanently connected reference cable with air compensation)							
Electromagnetic compatibility	Stray radiation acc. to EN 50081-2, noise immunity acc. to EN 50082-2							
Design configuration								
Electrical connection	- Cable connection M16 x 1.5 with terminal strip or permanent reference cable connection - Round plug M 12 x 1 with FPG							
Process connections	Modular system with loose pressure screw M38x1,5 and O-ring made from EPDM, Viton a.A. Flush-mounted and welded membrane, full CrNiSt, EHEDG-certified.							
Materials	Field housing CrNiSt 1.4301 - Transparent display cover with safety glass 1.4301 (type 100) Process connection and adaptor 1.4404, process membrane 1.4435/1.4404							
Filling liquid	PZM: Silicon oil (safe for nutritional use)				VRM: Vegetable oil, glycerine, silicon oil, white oil			
Display and operating module								
Display	LCD with 4-digit numerical value display and 5-digit alphanumeric display with additional information							
Displayed units	mbar, bar, psi, kpa, mH2O and %							
Additional displays	Display of output signal in mA, sensor temperature, range transgressions							
Operation	All parameters can be set in the parameter menu, using the 3 buttons below the digital display, adjustment of "zero" and "range" using 2 buttons							
Auxiliary energy								
Power supply / working resistance	9-36 V DC,		max. permitted residual ripple 1 V _{ss}			R _B = V _S - 9V : 0.022 A		
Effect of supply voltage	$< \pm 3 \mu\text{A}$, in the event of changes in the voltage supply							
Accessories for type 100 and 101								
Process connection adapter	see order information							
* optionally with WAZ 3.1B (EN10204)								
Accessories for type 101								
OPUS display module	External operating module, CrNiSt IP 67, 41 x 70 mm, with 0.5 m cable and M 16 x 0.75 round plug / locking screw M 16x0,75, CrNiSt, IP 67 included in delivery							

PN/PZM-VRM-100/D-e-08-1/2

Flush-mounted pressure and level transmitter - PZM / VRM modular system...Series 100 -

DIMENSIONAL DRAWINGS

PIEZOMESS 100 ... _K(M)

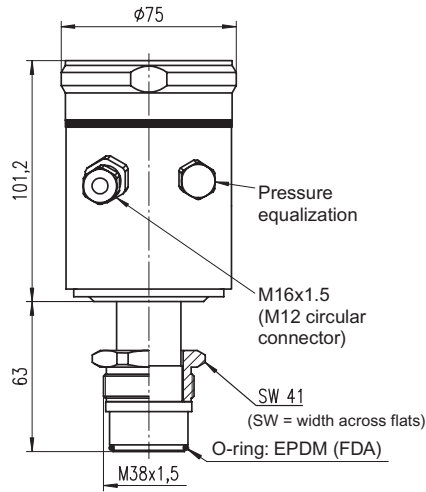

Field housing with integrated display
(stainless steel, IP67 EN 60529)

VARIMESS 100 ... _K(M)

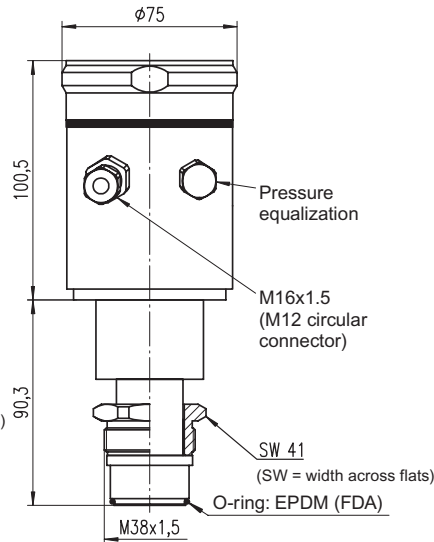

Field housing with integrated display
(stainless steel, IP67 EN 60529)

PIEZOMESS / VARIMESS 101 ... _K(M)

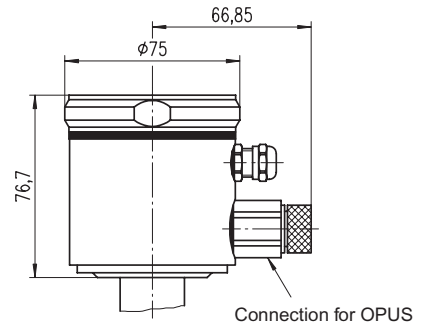

Field housing for OPUS
(stainless steel, IP67 EN 60529)

Process connection adapter : (other constructions on request)

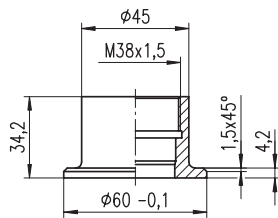

zem / VPM_T (PE1)
Welding socket VPM (tank)

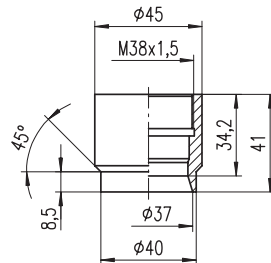

zem / VPM_R4 (PE2)
Welding socket VPM (pipe)

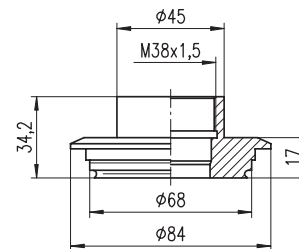

zfl / VA (PV6)
VARIVENT flange d=68mm

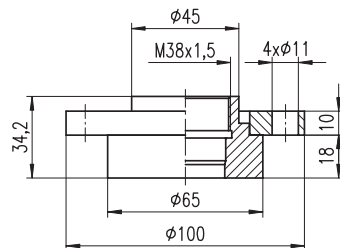

zfl / DRD (PD6)
DRD flange d=65mm

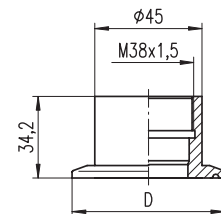

zfl / Cl... (PC5)
Triclamp flange
ISO 2852 2"...4"
DIN 32676 DN50...DN100

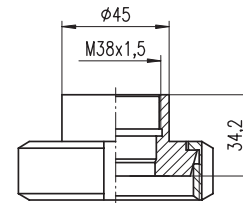

zfl / MG... (PM4, PM5)
Conical sleeve DIN 11851
DN40...DN100

ELECTRICAL CONNECTION

The electrical connection is made via screw clamps after the screw-type lid has been removed. The cable insertion usually takes place via an M 16x1.5 threaded connection, or optionally by means of an M 12x1 round plug. The test circuit connection ensures an uninterrupted output current measurement. We recommend the use of a cable with an air-equalisation tube in areas, especially in areas with high humidity levels.

	M16x1 5 with reference cable 4-20 mA (2-wire)	M16 x 1.5 with cable connection 4-20 mA (2-wire)	M12 round plug, 4-20 mA (2-wire)
GND	white	GND	
+ supply	red	1	1
- supply	black	2	3

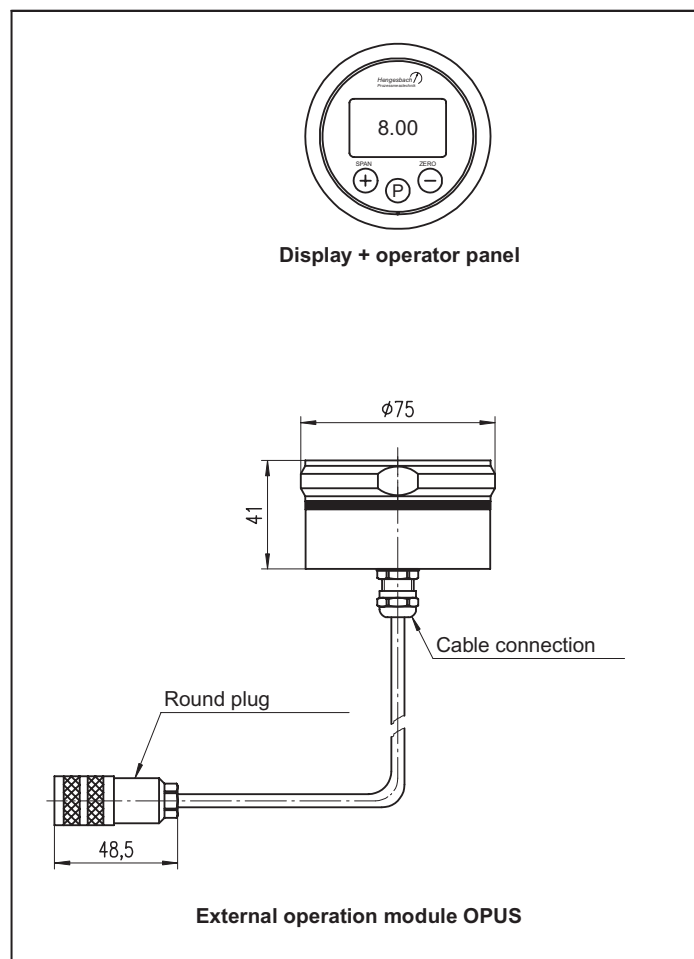

Flush-mounted pressure and level transmitter - PZM / VRM modular system...Series 100 -



ORDER INFORMATION FOR PIEZOMESS (PZM 100/101)

Electronics	
100	4-20 mA, LCD display, TD 01:10
101	4-20 mA, operated with Opus, TD 01:10

Type of pressure / measuring range (R = relative pressure or A = absolute pressure) - all vacuum ranges also possible -		
0.35	bar R	max. overload 1 bar
1	bar R	max. overload 3 bar
2.5	bar R	max. overload 8 bar
5	bar R	max. overload 15 bar
10	bar R	max. overload 30 bar
30	bar R	max. overload 90 bar
100	bar R	max. overload 250 bar
0.35	bar A	max. overload 1 bar
1	bar A	max. overload 3 bar
2.5	bar A	max. overload 8 bar
5	bar A	max. overload 15 bar
10	bar A	max. overload 30 bar
30	bar A	max. overload 90 bar
100	bar A	max. overload 250 bar
CC	Adjusted measuring range (in the case of a deviation from the nominal measuring range: please enter plain text with indication in bar)	

Electrical connection	
K	Cable connection M 16 x 1.5
M	Round plug M 12 x 1
W	Right-angle plug connection EN 175301-803 (not for 100)
R	Reference cable, 1 m, permanent connection other lengths to be specified in plain text (max. 80 m)

Design options	
T1	Normal temperature version
T2	High-temperature version up to 200°C

Flush-mounted pressure and level transmitter - PZM / VRM modular system...Series 100 -



ORDER INFORMATION FOR VARIMESS (VRM 100/101)

Electronics	
100	4-20 mA, LCD display, TD 01:10
101	4-20 mA, operated with Opus, TD 01:10

Type of pressure / measuring range (R = relative pressure or A = absolute pressure) - all vacuum ranges also possible -		
2	bar R	max. overload 18 bar
4	bar R	max. overload 25 bar
10	bar R	max. overload 40 bar
20	bar R	max. overload 40 bar
40	bar R	max. overload 60 bar
70	bar R	max. overload 105 bar
-1...4	bar R	max. overload 25 bar
-1...10	bar R	max. overload 40 bar
-1...20	bar R	max. overload 40 bar
4	bar A	max. overload 25 bar
10	bar A	max. overload 40 bar
20	bar A	max. overload 40 bar
40	bar A	max. overload 60 bar
70	bar A	max. overload 105 bar
CC	Adjusted measuring range (in the case of a deviation from the nominal measuring range: please enter plain text with indication in bar)	

Electrical connection	
K	Cable connection M 16 x 1.5
M	Round plug M 12 x 1
W	Right-angle plug connection EN 175301-803 (not for 100)
R	Reference cable, 1 m, permanent connection other lengths to be specified in plain text (max. 80 m)

VRM			
-----	--	--	--

Flush-mounted pressure and level transmitter - PZM / VRM modular system...Series 100 -



ORDER INFORMATION FOR ACCESSORIES PZM + VRM 100/101

Process adaptors	(please order separately)	
VPM welded socket \varnothing 60, with collar, 1.4404 (316 L)	zem/VPM_T	PE1
VPM welded socket for pipe, \varnothing 40, 1.4404 (316L)	zem/VPM_R4	PE2
VPM welded socket, \varnothing 53, 1.4404 (316L)	zem/VPM_R5	PE3
VPM welded socket \varnothing 45, 1.4404 (316 L) (pipe installation)	zem/VPM_R	PE4
VPM welded socket \varnothing 60, without collar, 1.4404 (316 L)	zem/VPM_TV	PE6
DRD flange DN 50, 1.4404 (316 L)	zfi/DRD	PD6
Conical sleeve with groove nut, DIN 11851, DN 40 / PN 40, 1.4404 (316 L)	zfi/MG40	PM4
Conical sleeve with groove nut, DIN 11851, DN 50 / PN 50, 1.4404 (316 L)	zfi/MG50	PM5
VARIVENT flange d = 68, DN 40-125 / PN 40, 1.4404 (316 L)	zfi/VA	PV6
Triclamp ISO 2852, DN 50 / 2", 1.4404 (316 L)	zfi/CL2	PC5
SMS DN 1½" (DN 38), 1.4404 (316 L), groove nut	zfi/SMS38	PS3
SMS DN 2" (DN 51), 1.4404 (316 L), groove nut	zfi/SMS51	PS5
Flange DIN 2527 DN 50 PN 25/40, 1.4571 (316 Ti)	zfi/FLA50	PF5
Flange DIN 2527 DN 80 PN 25/40, 1.4571 (316 Ti)	zfi/FLA80	PF8
Flange DIN 2501 Form C, DN 50 PN 40, 1.4571 (316 Ti)	zfi/FL50	PL5
Flange DIN 2501 Form C, DN 80 PN 40, 1.4571 (316 Ti)	zfi/FL80	PL8
Other process adaptors		P99

Accessories / assembly components	
External operating module OPUS, for electronics 101	OPUS
EPDM O-ring for PZM / VRM (with FDA authorisation)	ZOR
DRD welded block flange for PD6 process connection, DRD, 1.4435 (316 L)	ZEB
Flat seal made from EPDM for DRD welded block flange	ZDE
Flat seal made from Vito, for DRD welded block flange	ZDV
Flat seal made from Gore-Tex for DRD welded block flange	ZD9
4 fastening screws for DRD welded block flange	ZDS
Welding dummy, for PZM / VRM, Ms 58	ZEP
Sealing stopper for PZM / VRM, 1.4404 (316 L)	ZVP
Reference cable with pressure equalisation capillaries per metre or part thereof, made from PUR	ZKP
Pressure equalisation casing with ventilation filter - Wall mounting, can be used for all pressure transducers -	ZDA
Acceptance certificate, acc. to EN 10204 for welded accessories - per order -	WZ 31 (3.1B)

Our products are constantly in further development, therefore subjects to modifications.

PN/PZM-VRM-100/D-e-08-1/8