

Flange resistance thermometer

- Type TP 17 / TP 18 -



Version example: TP17 WITH MILKING PIPE CONNECTION



CHARACTERISTICS

- "FR" HOUSING IN IP 67
- WITH SINGLE OR DOUBLE PT100
- CIP-COMPATIBLE INSTALLATION METHOD
- OPTIONALLY AVAILABLE WITH MEASURING TRANSDUCER
- FLANGE VERSIONS:
 - MILKING PIPE CONNECTION ACCORDING TO DIN 11851
 - TRI-CLAMP ACCORDING TO ISO 2852

DESCRIPTION

The flange resistance thermometer **type TP17 / TP18** in its versions with or without a transmitter is a high-performance, robust and universally useful device for process measuring technology, the food industry, the pharmaceutical industry, etc., made entirely of stainless steel and including the most common process connections

The temperature sensor is a PT100 platinum resistance in accuracy class A and in accordance with EN 60751. Accuracy classes B 1/2, 1/3, 1/10 DIN or class B are optionally available. The measuring inserts are single or double PT 100s, which can be exchanged. The utilisation of the measuring inserts must be adapted to the requirements with regard to temperature, length, flexibility, vibration resistance and measuring accuracy. Devices with a tapered sensor tip and particularly short half-life values are, for example, available on request for regulatory processes.

The exchangeable measuring insert ensures that any exchange of the sensors that may become necessary can take place easily and rapidly without having to take the system out of operation or drain any tanks. If the measuring points are sensitive, for example in the food or pharmaceutical industry, corresponding hygienic types and versions are available. Cleaning can be carried out with all the media / fluids (CIP, etc.) common in this industrial sector.

The design of IP 67 offers a reliable guarantee with regard to sealing and long holding times, even under extreme conditions of use. The use of analog or programmable transmitters is optional for longer transmission distances. The QUICKTEMP series is particularly recommended for measuring points that require calibration.

T-TP17-TP18-D-e-08-1/1

Flange resistance thermometer

- Type TP 17 / TP 18 -



TECHNICAL DATA

Design configuration	
Type	field housing (Cr Ni ST)
Temperature sensor	PT 100 acc. to EN 60751, exchangeable measuring insert (standard), insert tube 1.4571
Measuring insert, electrical	1 x PT 100 in a 2-, 3- or 4-wire circuit, standard: 1 x 3-wire circuit, Class A, 2 x PT 100 in 2- or 3-wire circuit
Electrical connection	- M16 x 1.5 cable connection, MS-nickel-plated, - optional: M12 x 1 round plug, 4-pin
Accuracy	- standard: Tolerance class A according to EN 60751, - optional: Tolerance categories B 1/10, 1/5, 1/3, 1/2
Response time	T05 (measured in water): 6 s (design-dependent, d = 6 mm), < 4 s with tapered sensor tip, on request
Temperature of measuring material	T _{max} at the sensor = -20... +200°C
Housing material	stainless steel 1.4301 (standard field housing)
Sensor material	stainless steel 1.4571, optional 316L = 1.4435 or 1.4404, welded design, optional: high surface quality
Sensor diameter	standard: continuously smooth, d = 6 mm, optional: tapered sensor tip d = 4 mm (exchangeable measuring insert) tapered sensor tip d = 3 mm or 2 mm (non-exchangeable measuring insert)
Sensor length	- 50 mm, 100 mm (standard) - deviating lengths on request
Type of protection	EN 60529, IP 67 with cable connection, optionally with cable output
Permissible pressure	PN = 10 bar, depending on design and temperature
CE conformity	EMV guidelines are met, CE symbol
Process connections	
	- TP17/TW59...T300: according to DIN 11851, with tapered connection and a grooved union nut DN10...DN100 - TP18/TW59...T279: according to ISO 2852, with triclamp flange ½"...2 ½", DN10...DN100, according to DIN 32676 - optional: with a rapid-response sensor tip
Accessories	
	(please order separately, see data sheet on WTH field construction overview)
Parts for assembly	
Options	
Electrical connection	-- ceramic connection base -- flexible connection wires -- sheathed cable version (vibration-resistant version) -- transmitter TE 42, programmable, 4...20 mA, 2-wire switch (standard) -- transmitter TE 41, programmable, galvanically separated -- transmitter TE 52, HART -- transmitter TE 82, PA
Calibration	factory calibration, calibration certificate (3-point or 5-point), with DKD standard
Certificates	material certificate according to EN 10204

T-TP17-TP18-D-08-1/2

Flange resistance thermometer

- Type TP 17 / TP 18 -

DIMENSIONAL DRAWINGS

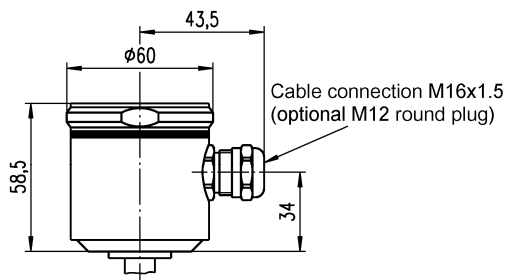

Field housing (stainless steel, IP67 EN 60529)
Connection head H

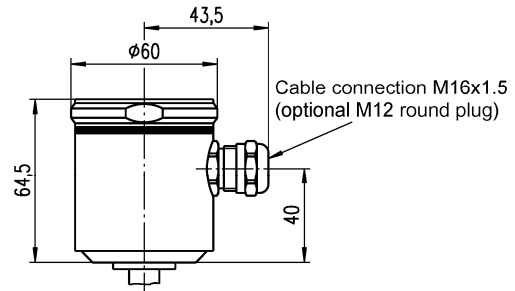

Field housing (stainless steel, IP67 EN 60529)
Connection head P (for Profibus)

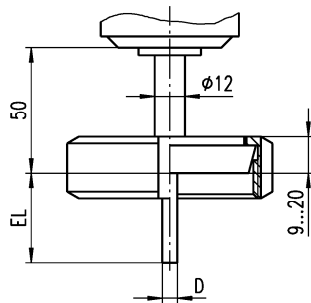

TP17 / TW59 ... T300
Tapered connection with groove nut
DIN 11851 DN10 ... DN100

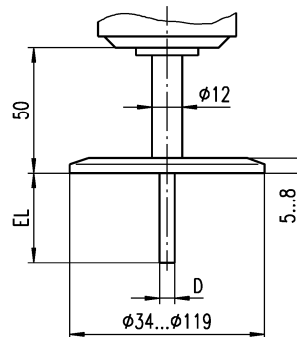

TP18 / TW59 ... T279
Triclamp flange
ISO 2852 1/2" ... 2 1/2"
DIN 32676 DN10 ... DN100

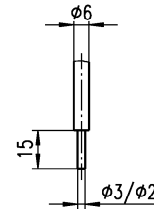

Option:
tapered sensor tip Ø3/2mm

Note:
Sensor Ø (diameter) = 6 mm (standard)
Insertion length (EL) = 100 mm (standard)

ELECTRICAL CONNECTION

(Version example: M12 round plug)

Connection with measuring transducer*

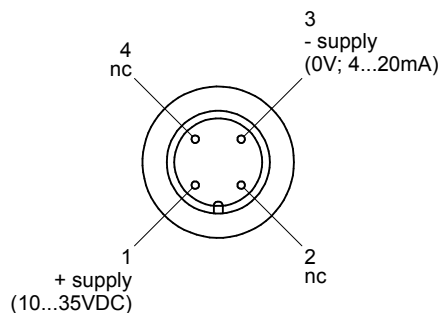

Addressing times for WTH PT100

Apart from the protective pipe at the measuring point, the addressing time is mainly determined by the heat transport:

- Medium, flow speed, etc.
- Heat capacity

Higher flow speeds and heat capacities considerably reduce the addressing time. It is indicated how long it will take until the measuring value reaches 50% or 90% of the final value

* connection without measuring transducer see field label

Flange resistance thermometer

- Type TP 17 / TP 18 -



ORDER INFORMATION

Sensor type, tolerance class, switch system	
A	1 x PT 100, class A, 2-wire
B	1 x PT 100, class A, 3-wire
C	1 x PT 100, class A, 4-wire
D	2 x PT 100, class A, 2-wire
E	2 x PT 100, class A, 3-wire

Connection head	
H	Field housing, 1.4301, M16 x 1.5
P	Profibus housing (raised field housing)
K	BUKH, polyamide PA (for double transmitter)
1	Form B, aluminium pressure casting
9	Other

Installation length / process connection			Type
05	50 mm	DIN 11851	T300
10	100 mm	DIN 11851	T300
20	160 mm	DIN 11851	T300
30	200 mm	DIN 11851	T300
50	250 mm	DIN 11851	T300
70	300 mm	DIN 11851	T300
80	400 mm	DIN 11851	T300
Cl ½	½"	ISO 2852	T279
Cl 1	1"	ISO 2852	T279
Cl 1 ½	1 ½"	ISO 2852	T279
Cl 2	2"	ISO 2852	T279
Cl 2 ½	2 ½"	ISO 2852	T279
90	Other lengths		

Version output / measuring range		
K0	00	Resistance output
L0		Transmitter 4-20 mA, 2-wire technology
	30	0 - 50° C
	40	0 - 100° C
	50	0 - 150° C
	60	0 - 200° C
	70	0 - 300° C
	80	0 - 400° C
	99	Other measuring ranges

TP17/TW59	<input type="checkbox"/>	<input type="checkbox"/>	<input type="checkbox"/>	<input type="checkbox"/>	<input type="checkbox"/>	T300, DIN 11851
TP18/TW59	<input type="checkbox"/>	<input type="checkbox"/>	<input type="checkbox"/>	<input type="checkbox"/>	<input type="checkbox"/>	T279 (Tri-Clamp)

ORDER INFORMATION FOR ACCESSORIES / ADD-ON PARTS

Options	(to be specified in plain text)
Transmitter (programmable), not galvanically separated	TE 4200
Transmitter (programmable) galvanically separated	TE 4101
Transmitter (programmable), galvanically separated EX	TE 4111 EX
HART transmitter	TE 52
Profibus PA transmitter	TE 82
Configuration set, incl. adaptor and software for TE 41/42	TZ 41/42
Tapered sensor tip D = 3 mm or 4 mm	
Accuracy class 1/3 DIN B (per PT 100)	
Accuracy class 1/5 DIN B (per PT 100)	
Accuracy class 1/10 DIN B (per PT 100)	
Sheathed cable version (vibration-resistant version)	
DKD calibration certificate	=> approved by an accredited DKD laboratory
Exchangeable measuring insert, d = 3 mm	
Neck pipe L = 75 mm, d = 12 mm	- please state other lengths -
M12 x 1 plug, 4-pin	

Our products are constantly in further development, therefore subjects to modifications.

T-TP17-TP18-D-08-1/4